

MODEL LIGHTING 101

By Kirk Schermerhorn

Weathering, Accurizing parts, Kit-Bashing, all of these are wonderful ways to add realism to a model. But for the ultimate in realism there is nothing like a well-lit model. To light a model it is important to understand the various light sources that are available, how to mount them in your model, how to wire them, and most importantly, how to do all of the above without electrocuting yourself or burning your house down!

Model Modifications and Preperation

So you've chosen a specific model kit that you want to light. You will need to consider several things to determine if it will be feasible to light your kit.

First you will want to study photos, videos, etc to determine the location and color of the lights. Next you will want to consider what type of lighting you will install. Look at the parts in your kit and verify if it has enough hollow spaces to accommodate the light sources, wires, and other electronics you might be installing. Internal space also is a factor in heat build up. The smaller the internal lighted spaces, the quicker heat can build up in side them. Are the areas that need to be lit clear? Can you buy clear after market parts that you can use to replace the kit parts that aren't clear, or can you cut or drill out the areas that need lighting and make the clear parts yourself out of common easy to acquire materials. Generally styrene kits best lend themselves to this type of modification. Simple lighting can even be installed in resin kits if you have the patients and steady hand necessary to hollow it out to accommodate lighting components. If the model you have chosen can be modified as described, then you are ready to proceed.

If the model has no clear parts, than you will need to cut out the opaque material from the areas you want to light. If the area is small and round than it is simply a matter of drilling it out with the proper size bit in a pin vise. But frequently the areas you want to light will be large and most of the time will not be round. If you have a steady hand you could score around the area with a good sharp #11 blade and slowly cut it out. If you're like me you would end up slipping and creating another area you will have to fill and sand. I like to drill small holes all around the edge perforating it, then I cut around the perforation with my hobby knife and clean up the edges of the hole with files and sanding tools.

Once the opaque areas have been cut out, you will want to replace them with a clear part of the correct color. You can buy high quality after market parts from a variety of sources, and for many different kits. If you can find these parts for your model, that is by far the simplest way to go. If the area is relatively flat you could simply trim a piece of colored filter material to fit and attach it to the inside of the part. You can buy sets of various colored rectangular filter sheets at some camera stores. For clear parts with more complex shapes it gets a lot more complicated and may require a knowledge of vacu-forming or making molds from the original parts and casting your own clear ones. Sometimes the clear parts that come with your model may be totally clear and you will need to color them. This can be done by backing the clear piece with a piece of colored filter material or, better yet, you can paint it with a transparent paint. For example Humbrol makes several "Clear colors". You may also want to consider putting a piece of "onion skin" tracing paper between the light source and your part. This will help diffuse the light and give it a nice soft glow.

Even though the areas of the model you don't want to light are not clear, light will still shine through them if you don't do something to block it. One way to do this is to paint the inside of the model flat black. Once the black paint dries, check for "light leaks" and touch up as necessary. Once the flat black is completely cured you could paint over it with gloss white or silver. This may seem counter productive after the flat black, but it helps reflect the light around the inside of the model and distribute it more evenly.

You will need to secure the bulbs and any electronics to the inside of the model so they won't rattle around in there and cause wires to break loose. If you want precision placement of your bulbs or light sources you

can secure things in place by cutting custom parts out of styrene. It placement is not crucial, or to secure wires and other components in place, you can use a dab of silicone rubber to tack them in place. I like to mount as few parts inside the model as possible and try to keep it to just light sources and wires. If you keep power sources and electronic circuits outside the model in the base you can get at them readily for repair or replacement.

You will most likely need to build a stand for the model that will hold the power source and other electronics in its base, have a hollow stem large enough to accommodate all the wires and be stout enough to support the weight of the model. Put the power switch to turn it on and off with in the base also. For a power switch I recommend a momentary contact switch. This allows you to light the ship up to show it off, but turns back off when you release it. This may not allow for prolonged viewing but it will definitely save you money if your model is battery powered and can also help prevent heat build up from the light sources.

Those are some of the construction issues you will have to deal with, now lets look at the different light sources that are available.

Incandescent Bulbs

Incandescent bulbs are the type that produce light by passing electrical current to heat a thin filament causing it to give off heat and light. They are very common and would include the bulbs in your house, the one in your flashlight, the dome light in your car, etc.

On the positive side, they are inexpensive, small, easily obtained, easy to wire, and the light from them shines out in all directions so a small bulb can light a large interior space.

On the negative side, they have a limited lifetime and they produce heat. One of the best ways to extend the life and control heat is to light the model for short periods of time only. The simplest way to accomplish this is to make your "on" switch a normally open momentary contact switch. When you push the switch the model lights up, when you release the switch the model goes back off. This discourages extended viewing time and prevents it from being accidentally left on so the next morning you don't find your pride and joy a gooey luminescent blob of styrene!

But no matter how little you light it, chances are the bulbs will burn out. You could be clever and camouflage a "repair hatch" in to the models own details, this could be a simple matter, or a nightmare depending on the model you use. The only other alternatives are to enjoy it as an unlit model or tear into it, replace the bulb and rebuild the kit. Lets face it, if your like me, you don't have enough time to build all those unopened kits, much less any to spare revisiting old projects you already completed!

All bulbs have two important ratings you will need to know. That is their Voltage and Current ratings. Voltage and Current both contribute to how bright a bulb burns, so the higher both of those ratings are the brighter it will glow, and the more Heat it will put out. So try not to use any bigger bulb that what you need to do the job adequately. As well, higher current ratings means that you will need to use a correspondingly larger amperage power supply.

Incandescent bulbs can be wired in two different configurations, series or parallel.

In the series circuit shown below the bulbs are all wired in a continuous chain. In this configuration the bulbs may all be of different voltages so long as the total voltage ratings of all the bulbs added together is equal to the voltage of your power supply. Design the circuit so the Power supply voltage and the total bulb voltages are as close to each other as possible. If the Power supply voltage is higher than the bulbs it will burn them out prematurely or if the total voltage of the bulbs is much higher than the power supply voltage, than they will glow too dim. Try to balance them as closely as possible.

Also, in a series circuit the bulbs must have the same current rating. In a series circuit like this the current will be equal going through all the bulbs and if they do not all have the same current rating the higher rated bulbs would cause too much current to flow through the lower rated bulbs causing them to burn out very quickly.

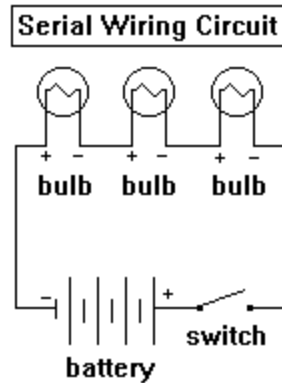

For example, if you wanted to light a kit in this configuration with 3 bulbs. 2 rated at 6V and the third at 12V and all three rated at 80 mA (remember, in series current must be equal!) then you would need a 24V DC power supply rated at no less than 80 mA. A 100 mA power supply would be best since it never hurts to get one that can provide a little more current than you need. The basic rule of thumb for a series circuit is: the voltage of the power supply must equal the sum of all the voltage drops across the resistive elements (bulbs, resistors, capacitors, LEDs, etc.) while the current rating of the power supply must be no less than the total current demanded by the circuit.

A major disadvantage of a series circuit is that if one bulb burns out current can no longer flow through any of the circuit and nothing will light anymore until the faulty component is replaced. This is why I much prefer the second method of wiring, parallel wiring.

In the Parallel circuit shown below one side of all the bulbs go to the power switch and the other side goes back to the power source. In this configuration each bulb has the same voltage dropped across it, which is going to be the same as the power supply voltage. The bulbs should not be higher than the power supply or they would all glow dimly. Conversely you wouldn't want the power supply to be higher than the bulbs; it would burn them all out pretty quickly. Additionally, in a parallel circuit each separate path across the batteries can allow a different amount of current flow. You need to be sure your power supply can provide a minimum current equal to the sum of the currents flowing through all of the bulbs. For example, lets say that in the circuit below the bulbs are both 6V and our power supply is also a 6V (remember they must be equal in a parallel circuit). One bulb draws 50 mA and the other uses 80 mA. Then the power supply you use must be capable of supplying at least 130 mA. ($50 \text{ mA} + 80 \text{ mA} = 130 \text{ mA}$) The beauty of this circuit is that if one bulb burns out all the rest keep burning.

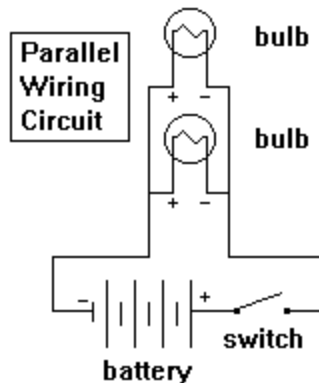

If you don't want to worry about the inconveniences of burned out bulbs, than maybe LED's are the choice for you!

LED's

LED's or light emitting diodes are a semi-conductor device that come in several colors including red, green, yellow, and recently have become available in white and blue. LED's have a very long life. How long? I can not say for sure other than to say that I have worked in electronics repair for over 20 years and in the thousands of devices I have had to work on that have LED's in them I have rarely had to replace one. LED's also give off very little heat. On the negative side, they are a little more expensive than incandescent bulbs but are still relatively inexpensive. They have a limited viewing angle so you may need several of them to light the same area as an incandescent bulb. Recently 360 degree white LEDs with a have become available that help overcome this limitation. They are bright enough for most applications, but not quite as bright as some incandescent bulbs.

Wiring an LED is a little more complicated because they require a current limiting resistor in series with them to limit the current going through them to a safe limit. The value of the resistor will vary depending on the LED you use and your power supply voltage. The following formula is used to calculate the value of the resistor:

$$\text{RESISTOR VALUE} = \frac{V_{in} - V_{led}}{I_{led}}$$

" V_{in} " is your power supply voltage; " V_{led} " and " I_{led} " refer to the voltage rating and the maximum allowable forward current (in Amps) of your LED. These values can be obtained from the LED's specification sheet. For example, let's say your power supply is 6 volts and your LED has a voltage drop of 2 volts and a max forward current of 30mA, To calculate the resistor value use the formula above as shown here: 6 volts (power supply voltage) – 2 volts (LED voltage rating) divided by .03 Amps (the LEDs maximum forward current rating) = 133 ohms. Most LED current ratings are expressed as milliamps. Since the formula uses amps you must be sure your decimal is in the right when you plug it in the formula. Note that in the example above our LEDs maximum forward current was 30 *milliamps* or .03 *Amps* as plugged into our formula. Resistors come in standard values so you would probably not be able to find a 133-ohm resistor. Resistors do come in standard values of 130 and 150 ohms. In this case you would want to use the 150-ohm resistor. Even though 130 ohms is closer to the calculated value of the resistor you want go to the next highest value resistor to the calculated value. Using a resistor with a value below the calculated value will allow too much current flow through your LED possibly destroying it.

LED's are also polarity sensitive, meaning that it must be wired in the correct direction in order to conduct current. An LED has an Anode side and a Cathode side, the Anode must connect to the Positive side of your circuit and the Cathode side must connect to the negative side of your circuit. An LED has a long lead and a short lead plus a flat spot on one side. The short lead and the corresponding flat spot on the side of an LED identifies it as the anode side, the remaining long lead identifies it as the cathode side.

If you are using several LED's of different colors and sizes you will want to calculate the series limiting resistor needed for each one based on the voltage of the power supply you plan to use. Next you would hook up each LED in series with its current limit resistor. You could the hook all the LED and resistor pairs up in parallel with each other. As with the light bulbs in the previous section you would add the individual LED currents together to get the minimum current your power supply would have to supply.

Cold Cathode Tubes (CCL)

Cold Cathode tubes are long small diameter cylindrical bulbs that look like miniature fluorescent tubes. They are suitable for lighting models and come in a variety of colors. Because of their long, thin dimensions they are best suited for lighting things such as Warp Nacelles or a rather large internal area of a model. They are considerably more expensive than Incandescent bulbs or LED's and require a special power supply. The wiring could vary depending on who you buy them from, but wiring instructions should be included. They do not run real hot, but do generate enough heat to cause potential damage if left on for extended periods of time.

You can get CCL tubes in several different lengths, diameters, and colors, along with their power supplies, from a couple of good mail order sources. If you only need white light, then some people like to buy small battery operated fluorescent lamps and rob the guts out of them to use in their model.

Electroluminescent Material

Electroluminescent material is the type of lighting you sometimes see in use in backlit LCD displays. The most common example that comes to mind is a Timex Indiglo watch. The light it puts out is similar to fluorescent, but it is very versatile. It comes in a thin flat sheet and also in small diameter tubular packages (EL wire). It is flexible, so you can bend it around things. It can also be trimmed to shape. It generates very little heat, but could still cause damage if left on too long or by putting too much in too confined a space. It is relatively expensive and needs a special power supply that is also not cheap, but if you have that one special spaceship that is near and dear to your heart that you want to build a lighted version of then there is quite simply not a finer source of lighting you can buy. Especially things like warp nacelles, engine exhaust, Sensor dishes.

Light Sheet comes with instructions on how to wire it, follow them closely! It is very important that you pick the right size power supply for the amount of lightsheet you plan to use. Too small a power supply will burn up or not light your project up. Too large and the lighting material will burn up.

Fiber Optics

Fiber Optics are not a light source, but a way to direct light to an area. Fiber Optics come in round strands in plastic or glass. Plastic fibers are preferred for modeling because they are flexible. You can buy raw unjacketed plastic fiber in sizes from .01 inch/ .025 mm up to .08 inch/ 2 mm. Because they are round, Fiber Optics are best used for things like running lights/navigation lights or round window ports.

To use Fiber Optics you will need to drill holes in the proper places on your ship's hull with a pin vise and a drill bit the same size as the fibers you will be using. Cut your fibers long enough to reach from the holes to your light source. Feed the fibers through the hole leaving a couple of millimeters sticking out of the hull and tack it in place with a small drop of super glue applied to the inside of the hull (5 minute epoxy is also a good glue to use; super glue can sometimes leave the fiber brittle from the crazing). If you have several fibers it is a good idea to gather them all into a single bundle and run them to your light source.

Fiber Optics provide a challenge to mask for painting. You can leave the excess sticking out of the model while you paint over them. Once the paint dries you can clip them off as flush to the surface of your model as possible. The drawbacks to this are that you risk marring your paint's surface and even with the best set of flush cutters you will still leave a noticeable bump. The second, and much more time consuming way, is to get a set of Waldron sub-miniature punches and cut out masking paper discs and apply them over your fibers before painting, paint your model, and then remove them carefully afterwards. Another way is to use a toothpick to apply liquid masking fluid (Humbrol's Maskol, for example, or any liquid latex like MoldBuilder) which you can then rub off after painting. The trick here is to keep your coats of paint from getting too thick, otherwise the discrepancy between the outer coat of paint and the fiber optic end is quite noticeable.

Power sources

There are 4 types of power sources that you could use in your model: 120 Volts AC, an AC adapter to output lower voltage AC or DC, DC battery power and finally voltage regulators.

120 Volts AC is what comes out of your wall sockets at home. It is impractical for use in models for two reasons: first of all, most of the lighting mentioned uses DC rather than AC current, and at a much lower voltage; secondly, it can potentially be very dangerous. The other two power sources are much simpler to work with and also much safer!

AC adapters plug into the wall, reduce that voltage to a lower value, and may convert it from AC to DC. Since all the circuits I have describe above use DC current it would be preferable to use an adapter that puts out DC. You will want to be sure you know the current demands of your circuits and make sure you select an adapter that is rated for at least that current or higher. For instance, suppose you have a model where you have 6 LEDs all in parallel with each other and a Light Sheet Light Drive in parallel with them. Two of your LED's have a forward current of 30mA, the other 4 have a forward current of 20mA, and finally the light drive has a input current of 220 mA. To find how much current your adapter must supply add all these currents together. Since $30+30+20+20+20+20+220=360$, your adapter would have to have an output current no less than 360mA. Always choose higher! You can buy power adapters with adjustable output voltages or ones with fixed voltages anywhere from 3 up to 24 volts. You can get them at Radio Shack, Circuit City, etc. They may be made for other devices, so just search around until you find one with a voltage and current output that match it.

With AC adapters you have the inconvenience of having to plug it in to show it off. Some modelers like to make their lighted kits fully self-contained, i.e. both the circuitry and power supply are enclosed. If so, then battery power is the way to go. You can use regular disposable batteries or you can get rechargeable batteries if you prefer.

Something you need to consider is the configuration of your batteries. As with other parts of a circuit, batteries behave differently when connected in series and in parallel. For example, the batteries in a flashlight are usually connected in series because the total voltage available to the bulb is the sum of the individual battery voltages. If your flashlight takes 4 "D" cell batteries then it can power a 6V bulb ($4 \times 1.5V$). Although the voltage you can supply increases as you add batteries the current capacity stays the same as a single cell no matter how many you add.

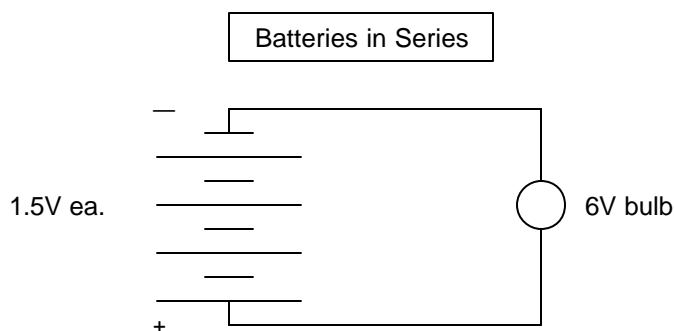

If you want to get longer viewing time out of the batteries in your lighted model then connect the cells in parallel. In this configuration, the voltage supplied to the circuit remains at that of a single battery but the current capacity is now the sum of all the batteries.

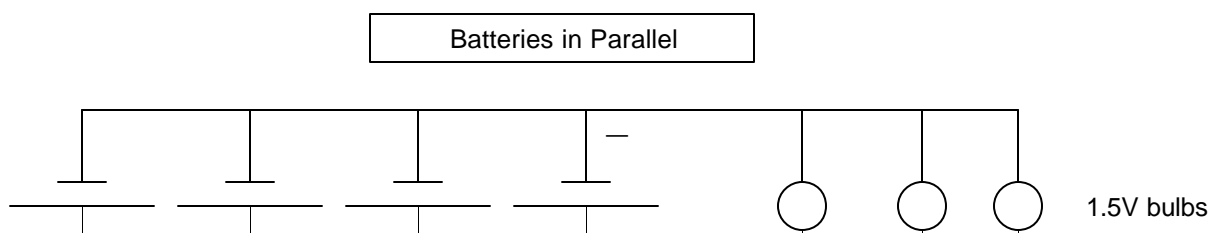

Voltage Regulators

Suppose you were designing a lighting system for a model and you had two different types of lighting that worked at different voltages. How would you power it? Would you use two separate power supplies, or is there a better way? Yes there is! With a voltage regulator you can take one DC voltage and convert it to a lower DC voltage. Voltage regulators are easy to obtain at your local electronics supply store and come from several different manufacturers. Attached at the end of this handout is a list of Voltage regulators available from one manufacturer. The left-hand column shows the output voltage and the third and fourth columns show the voltage range that can be applied to the input of the voltage regulator. Lets say your model will use some Light Sheet that runs at 9 volts and some regular bulbs that run at 6 volts. If you look at the list you will see that a 962 has a 6 volt output and will work with a 9 volt input (any voltage between 8 and 35 volts.). Now you can use a 9 volt adapter and, using the 962, convert it to 6 volts to power the bulbs.

Putting it all together

In the previous sections we looked at all the different types of lighting and the variety of ways to power them. Next lets bring it all together by figuring out how to wire and select the correct power supply for a relatively complex project that uses three different types of lighting. For our example lets say you have a classic "Federation" style starship you want to light and you intend to light it as follows: two blue CCL tubes for the warp nacelles, two red LED's for the Bussard collectors, 6 white LED's to light up the interiors of the primary and secondary hulls, and a sheet of blue light sheet that is 1x2 inches for the sensor dish. A bit of pre-planning would be advisable here, so lets start drawing out our circuit one element at a time starting with the component that uses the highest voltage, add the others elements in one by one, and finally add in a power supply at the end.

If we examine the power requirements from the data sheets I have added to the end of this handout for the different types of lighting we will find the following. The CCL tube supply requires 12 volts for optimal operation, the light sheet supply prefers 9 volts, and the LEDs can be made to work at any available voltage. So let's start drawing out our circuit. To begin with we will draw in a 12volt power supply. We can not calculate the current requirement until we add all the circuit elements and can add up all their current requirements. Next we will draw in the CCL tube supply and tubes using the supplied literature, which is attached at the end of the hand out, being sure we connect everything correctly as the power supply will be damaged if we do not.

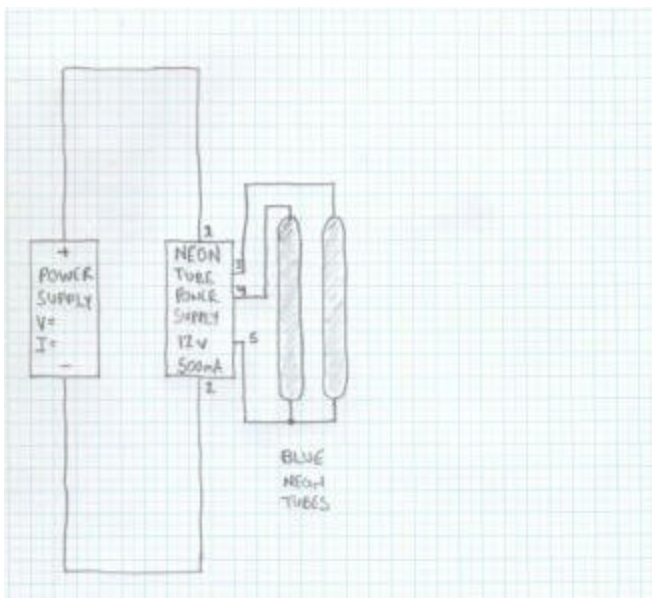

Next we will want to add in our light sheet. If we look at the light sheet data sheet we can see that the light drive which powers our light sheet has an operating voltage of 9 volts and draws a maximum of 75mA. We have already chosen a 12 volt power supply to power our CCL tubes so we will need to use a voltage regulator to drop that voltage down to 9 volt for our light drive. If you look at the list of voltage regulators, with the other data sheets at the end of this handout, you will see that there are three different 9 volt regulators listed. Two of these regulators have output currents of 1 amp and the other only 0.1 amp or 100 milliamps. Since we know already that our light drive uses 75 milliamps the 100 milliamp voltage regulator, the NTE 1902, should do the job. First we would connect the Voltage in or Vin pin of the regulator to the main 12 volt supply. The common pin, or ground pin, goes to the negative side of the main supply. Now attach the V out pin of the regulator, which is the 9 volts you want for the light sheet, to the “+” or DC IN pin on the light drive. The “-“ or COMMON pin of the light drive goes to ground pin of the regulator, which is the same as the power supply negative side. The light sheet is then connected between the AC and Common pins of the light drive

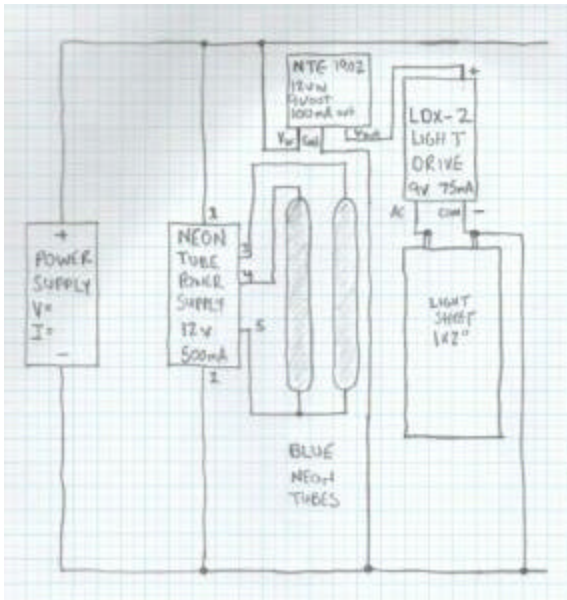

Finally, we will want to add in our LEDs. We will also figure the power consumption of our circuit so we can determine the amount of current our power supply will need to provide.

To add the LEDs into our circuit we will first need to calculate the correct size current limiting resistors to put in series with them. To determine this we will need to know the forward voltage and current of our LEDs. If we look below at the data sheets for our LEDs we can see that the red LEDs have a forward current of 20 milliamps and a forward voltage of 2 volts The white LEDs forward current is also 20 milliamps with a forward voltage of 4 volts.

Absolute Maximum Ratings (25° C)
 Power Dissipation: 60mW
 Forward Current: 20mA
Optoelectrical Characteristics (at 10mA)
 Forward Voltage: 2.0V
 Luminous Intensity: 6.3mcd
 Peak Wavelength: 650nm
 Short lead is Cathode (-) minus.

Color	DC Forward Voltage V _F (V)	
	Typ.	Max.
BLUE	3.6	4.0
GREEN	3.5	4.0
WHITE	3.6	4.0
Condition	I _F =20mA	

Now we will punch our numbers into the formula we introduced earlier, resistor value = $(V_{in} - V_{led}) / I_{led}$, and calculate or resistor values. For the red LED $(12 \text{ volts} - 2 \text{ volts}) / 0.02 \text{ amps} = 500 \text{ ohms}$, and for the white LED $(12 \text{ volts} - 4 \text{ volts}) / 0.02 \text{ amps} = 400 \text{ ohms}$. You would want to use 510 ohm resistors for the red LEDs and 430 ohm resistors for the white LEDs as these are the nearest standard sized resistors that are greater than the calculated values.

Once we add these to our circuit we can calculate how much total current our power supply must be capable of supplying. To do this we simply add up the current demand of each of the components hooked across our power supply. This would be 500 milliamps for the CCL tube supply plus 100 milliamps for the voltage regulator and 160 milliamps for the LEDs (6 x 20 milliamps) for a total of 760 milliamps. You may notice that I left out the 75 milliamps that the Light Drive uses. This is because it is hooked to the voltage regulator and not the power supply so its 75 milliamps will be part of the 100 milliamps that the regulator draws. We must be sure that our power supply can provide at least 760 milliamps. Better still you may want to get one larger than that so your power supply is not constantly operating at it's upper limit, in this case a 1 amp power supply would be good and a 12 volt 1 amp supply is pretty easy to find.

Our completed circuit should now be wired like the schematic below:

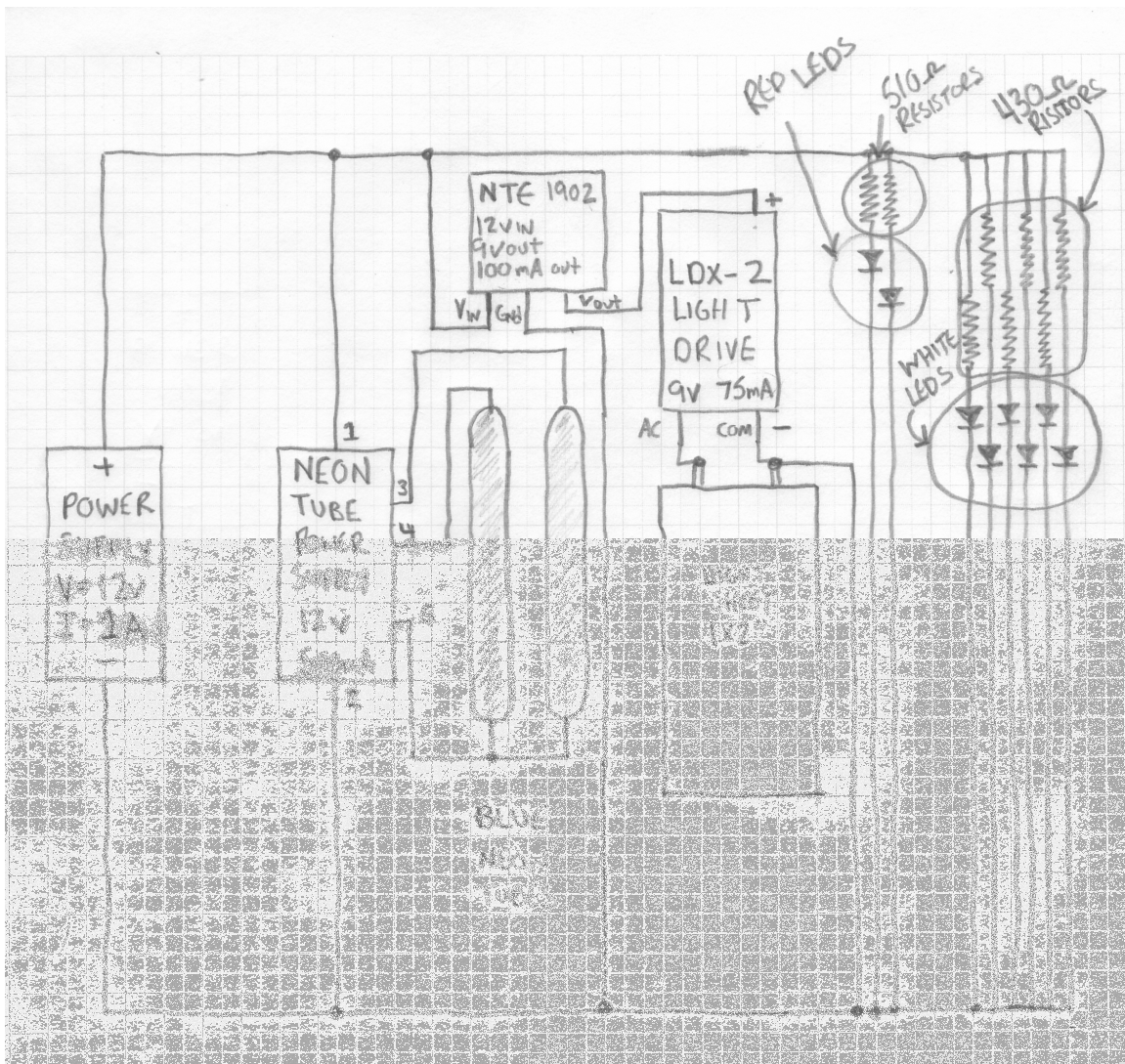

Tools for the job

The following is a list of tools and supplies you may want to have handy on your workbench for model lighting projects.

Multimeter- good for measuring voltage, resistance, continuity, and polarity.

Soldering Iron and Solder- needed for making electrical connections between components. You can get AC powered soldering irons, rechargeable ones, or butane gas powered ones.

Circuit designer's breadboard- good for hooking up and testing out your circuits prior to assembling them

Jumper leads - Lengths of wire with alligator clips at both ends, also useful in the design phase

Adjustable AC adapter- Also good for design work. Get one that has a wide range (i.e. 3V to 12V) since you will want to use the smallest possible voltage setting to test LEDs.

Wire- Various sizes and lengths of wire for hooking things up. You can buy various sizes of wire, both stranded and solid at Radio Shack or other electronic supply stores.

Electrical tape- Good for insulating wires and connections

Heat shrink tubing- even better for insulating. Slide a length over the wire or connection you want to insulate, apply heat to it and it shrinks around your connection.

Lighting Supplies

Here are several sources of lighting supplies that you may find helpful.

Miniatronics

Has bulbs, flasher circuits, LED's, switches, connectors, etc

<http://www.miniatronics.com/>

Miniatronics Corp. 561-K Acorn Street, Deer Park, NY 11729

1-800-942-9439 | FAX 631-242-7796

miniatronics@miniatronics.com

LightSheet systems

Premier source of electroluminescent material and power supplies to power them.

TrekFX@aol.com

319 Main Dunstable Road

Nashua NH 03062-1906

Phone: (603) 595-7146

FAX: (603) 595-9609

Fiber Optic Products, Inc.

They have standard fiberoptics and "sideglow" that shines out the sides rather than the ends. (Good for simulating phaser beams, etc.) Also LEDs and some other lighting supplies.

<http://www.fiberopticproducts.com/>

P.O. Box 779
Clearlake Oaks, Ca 95423
Ph: 707-998-3903

Mouser Electronics

Have many electronics components and supplies.

<http://www.mouser.com/>

1000 North Main Street
Mansfield, Texas 76063
(800) 346-6873
Fax: (817) 804-3899
E-mail: Sales@mouser.com

Dons Light and Magic

Don has some of the best lighting parts for Star Trek models. His add-on parts include clear resin pieces for the TOS & TMP E and Defiant, plus he markets a newly redesigned circuit board for the TOS E that provides blinking running lights, strobes for the Ion pod and a new 'spoke' warp engine effect (Ross is a little biased ~ he helped redesign the circuit with Don!)

<http://www.dlmparts.com/pages/1/index.htm>

don@dlmparts.com
Don Matthys
1116 7th Ave., N. #1
Fargo, ND 58102
701-235-3186

Fiberoptics Technology, Inc.

Unjacketed plastic fiber from 0.25 mm to 2 mm in dia. prices cheap, but \$25.00 charge if you order under \$200.00 worth. May want to go in with a friend on some.

<http://www.fiberoptix.com/>

Fiberoptics Technology, Inc.
12 Fiber Road, Pomfret, CT 06258
TOLLFREE: 1- 800- 433- 5248
FAX: 1- 800- 543- 2558

All Electronics Corporation

A veritable cornucopia of supplies! Has LEDs, bulbs, switches, CCL, small motors, and much, much more. Think they deal in surplus goods, so availability of some items could change from one catalogue to the next.

<http://www.allelectronics.com/>

Order Toll Free 1-888-826-5432
FAX (24 hours a day) 818-781-2653
ALL ELECTRONICS CORP
P.O. Box 567
Van Nuys, CA 91408-0567

Super Bright LEDs

Carry the phosphorous coated 360 degree LEDs

<http://www.superbrightleds.com/index.htm>

St.Louis, Missouri, 63031 USA

Tel: 314-972-6200

Solution Industries

Electroluminescent wire in various colors and diameters.

[Category Items - ThatsCoolWire.com](http://www.ThatsCoolWire.com)

1704 Seamist Drive - Suite 410

Houston, TX 77008

713-869-0500

More Information

To see many examples of lighted projects visit my friend, CultTVM an, at his web site at:

<http://www.culttvman.com/>

Be sure to check out Don Matthys Excelsior lighting project (The ship shown on the cover!) for a very detailed narrative of one of the finest lighted models I have ever seen!

The following sites have Additional information on electronics basics or lots of different circuits you can build, some of which may be usefull in your models:

http://ourworld.compuserve.com/homepages/Bill_Bowden/

<http://www.mrollins.com/circuit.html>